

Coffee System
Mira Traditional espresso coffee
POD machine, 1 group, 6.3 liter boiler

ITEM # _____

MODEL # _____

NAME # _____

SIS # _____

AIA # _____

602514 (MIRA1DCA)

 Traditional espresso coffee
 POD machine, 1 group, 6,3
 liter boiler, 4 programmable
 dosing program

Short Form Specification

Item No. _____

The MIRA line takes on the challenge of offering a dynamic outline with a sleek and streamlined design combining Stainless steel, Plexiglass and chromed components. Featuring the patented DCA group in place of the traditional brewing unit, the MIRA DCA open the way to professionals willing to work with single-serve E.S.E. coffee POD. The DCA system make professional brewing possible of 1 or 2 espresso from coffee POD on any MIRA models. Its technical features enable it to warrant consistently outstanding coffee quality throughout the day, while maintaining its reputation of quality and reliability that has resulting from a long-standing experience. Among its features, independent control boxes to control the volumetric commands, manual Steamglide lever to control the steam level horizontally and precisely via a ceramic cartridge, hot water dispenser with 2 programmable time-delay keys, steam dispenser with 1 programmable time-delay key

Main Features

- Automatic cleaning cycle.
- The MIRA line offers a dynamic outline with a sleek and streamlined design combining Stainless steel, Plexiglass and chromed components.
- Its technical features enable it to warrant consistently outstanding coffee quality throughout the day, while maintaining its reputation of quality and reliability that has resulting from a long-standing experience. Among its features, independent control boxes to control the volumetric commands, manual Steamglide lever to control the steam level horizontally and precisely via a ceramic cartridge, hot water dispenser with 2 programmable time-delay keys, steam dispenser with 1 programmable time-delay key.
- Featuring the patented DCA group in place of the traditional brewing unit, the MIRA DCA open the way to professionals willing to work with single-serve E.S.E. coffee POD. The DCA system make professional brewing possible of 1 or 2 espresso from coffee POD on any MIRA models.
- 4 programmable dosing keys.
- Traditional espresso coffee POD machine.

Construction

- Stainless steel body.
- Manual Steamglide lever.
- 1 group - 6.3 liter boiler.
- Manual hot water outlet.

Optional Accessories

- Steam outlet with adjustable flow PNC 871000
- Hot water outlet with adjustable flow PNC 871001
- Cappuccinatore/foamer device with two positions for hot milk and for foam only for machines without Steamair PNC 871011
- Cappuccino system/auto foam device by air injection for traditional machines only for machines without Steamair PNC 871012
- Teflon steam wand only for machines without Steamair PNC 871013
- Side milk refrigerator 8 liter nominal capacity for up to 4 liter milk containers PNC 871014
- Side milk refrigerator 8 liter nominal capacity for up to 4 liter milk containers with digital display PNC 871015
- Raised feet kit PNC 871041

APPROVAL: _____

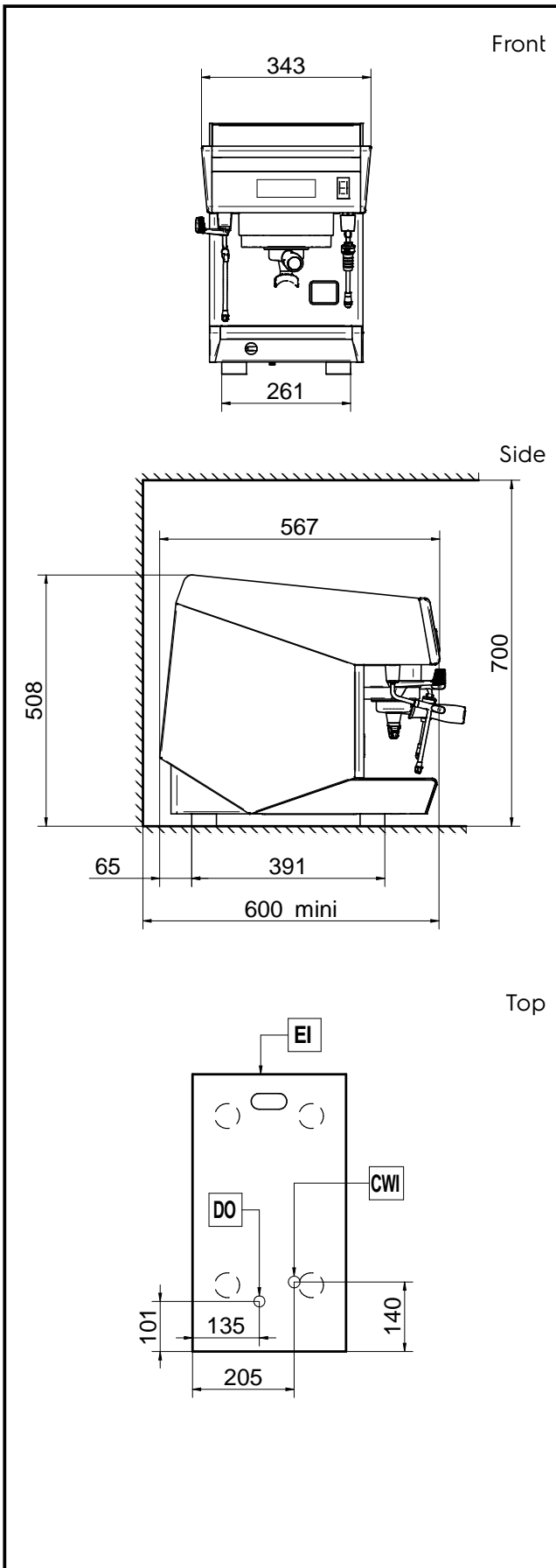

Electric

Supply voltage:

602514 (MIRA1DCA) 230 V/1N ph/50 Hz

Electrical power max.:

3 kW

Current consumption:

13 Amps

Plug type:

Water:

Cold water temperature

(min/max): 5 / 60 °C

Key Information:

External dimensions, Width: 343 mm

External dimensions, Depth: 570 mm

External dimensions, Height: 510 mm

Net weight: 41 kg

Shipping volume: 0.32 m³